

FRONT MOUNT

SINGLE ACTING HYDRAULIC TELESCOPIC CYLINDER

STANDARD RANGE

Value Element	Value Defined
Endurance	Augmented Cylinder Longevity
Payload	More Weight per Load
Tipping Time	More Loads per Day
Service Intervals	Increased Vehicle Working Time

Features	Benefits
Superior Quality Steel	Durability and Strength
Dimensions	Improved Strength
Final Stage Chroming	Corrosion Free with Superior Seal Life
Reduced Weight	Greater Payload
Reduced Oil Volume	Increased Tipping Time and Reduced Oil Cost
Reduced Maintenance	No need of Air Bleeding
Superior Sealing	No Oil Leakage in any climate
Easy bottom access	Faster re-pack
Dust Cover	Protects the Cylinder from Debris



FRONT MOUNT

SINGLE ACTING HYDRAULIC TELESCOPIC CYLINDER

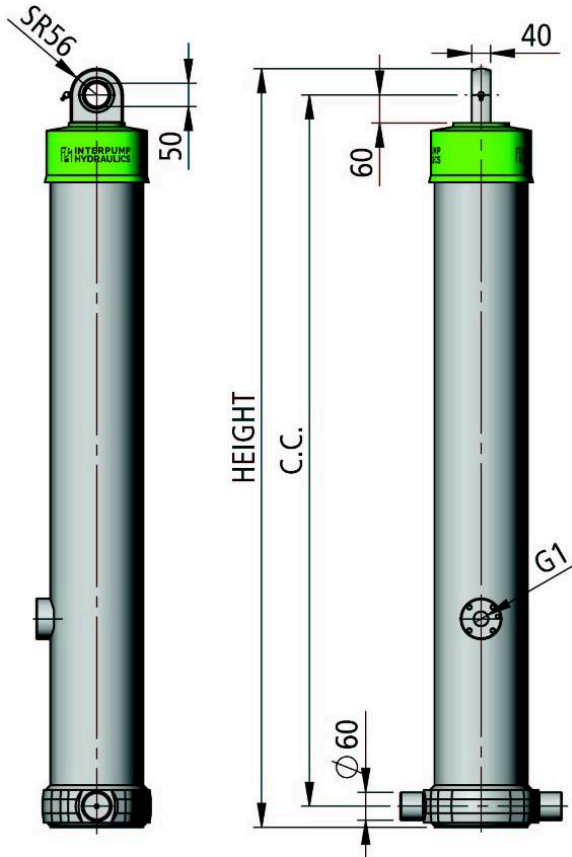

MODEL - STROKE DIA - EXT.No.	PART NUMBER	HEIGHT [mm]	C.C. [mm]	WEIGHT [kg]
HPF3290 116 3	4F12801163001	1471	1370	110
HPF3490 116 3	4F13601163003	1540	1439	115
HPF3820 116 3	4F14701163001	1686	1585	124
HPF5010 116 4	4F14701164001	1687	1586	140
HPF3280 135 3	4F12801353001	1475	1374	132
HPF3490 135 3	4F13601353004	1544	1443	137
HPF3820 135 3	4F14701353002	1690	1589	150
HPF4370 135 4	4F12801354001	1465	1374	145
HPF4650 135 4	4F13601354002	1544	1443	155
HPF4930 135 4	4F14301354001	1615	1514	158
HPF4010 154 4	4F12101544001	1388	1287	166
HPF4370 154 4	4F12801544001	1477	1376	175
HPF4370 154 4	4F12801544003	1476	1376	174
HPF4640 154 4	4F13601544002	1546	1445	185
HPF4930 154 4	4F14301544002	1617	1516	190
HPF5010 154 4	4F14701544002	1691	1591	200
HPF4580 154 5	4F11151545001	1303	1202	170
HPF5460 154 5	4F12801545001	1478	1377	186
HPF4350 174 4	4F12801744001	1478	1378	215
HPF4630 174 4	4F13601744001	1548	1447	225
HPF4910 174 4	4F14301744001	1619	1518	238
HPF5380 174 4	4F16001744002	1790	1664	265
HPF5670 174 4	4F16801744004	1864	1763	275
HPF5010 174 5	4F12101745001	1390	1289	215
HPF5180 174 5	4F12351745001	1424	1323	223
HPF5400 174 5	4F12801745004	1480	1379	230
HPF5450 174 5	4F12801745001	1480	1379	230
HPF5800 174 5	4F13601745002	1548	1448	238
HPF6150 174 5	4F14301745001	1622	1521	250
HPF6500 174 5	4F16001745004	1790	1689	280
HPF6730 174 5	4F16001745002	1791	1690	278
HPF7100 174 5	4F16801745001	1865	1764	290
HPF7100 174 5	4F16801745002	1865	1764	290
HPF7750 174 5	4F18001745002	1995	1894	310
HPF9030 174 5	4F20601745001	2269	2168	360
HPF6540 174 6	4F12801746001	1480	1376	245
HPF7380 174 6	4F14301746001	1620	1519	270
HPF5430 196 5	4F12801965001	1484	1383	280
HPF6130 196 5	4F14301965001	1624	1498	310
HPF6230 196 5	4F14701965001	1700	1598	325
HPF7080 196 5	4F16801965002	1870	1769	355
HPF7330 196 5	4F17301965001	1919	1818	365
HPF5150 196 6	4F10551966001	1255	1154	250
HPF6740 196 6	4F13101966001	1514	1413	305
HPF6940 196 6	4F13601966001	1554	1453	310
HPF7490 196 6	4F14701966001	1700	1599	340

REPAIR KIT

DIAM	EXTENSION N.	GUIDES KIT	SEALS KIT
116	3	K141001163003	K241001163004
116	4	K141001164002	K241001164004
135	3	K141001353005	K241001353003
135	4	K141001354007	K241001354005
154	3	K141001543002	K241001543002
154	4	K141001544004	K241001544003
154	5	K141001545005	K241001545004
174	4	K141001744002	K241001744002
174	5	K141001745002	K241001745003
174	6	K141001746005	K241001746005
196	5	K141001965002	K241001965002
196	6	K141001966002	K241001966002

FRONT MOUNT

SINGLE ACTING HYDRAULIC TELESCOPIC CYLINDER

STANDARD RANGE

Value Element	Value Defined
Endurance	Augmented Cylinder Longevity
Payload	More Weight per Load
Tipping Time	More Loads per Day
Service Intervals	Increased Vehicle Working Time

Features	Benefits
Superior Quality Steel	Durability and Strength
Dimensions	Improved Strength
Final Stage Chroming	Corrosion Free with Superior Seal Life
Reduced Weight	Greater Payload
Reduced Oil Volume	Increased Tipping Time and Reduced Oil Cost
Reduced Maintenance	No need of Air Bleeding
Superior Sealing	No Oil Leakage in any climate
Easy bottom access	Faster re-pack



FRONT MOUNT SINGLE ACTING HYDRAULIC TELESCOPIC CYLINDER

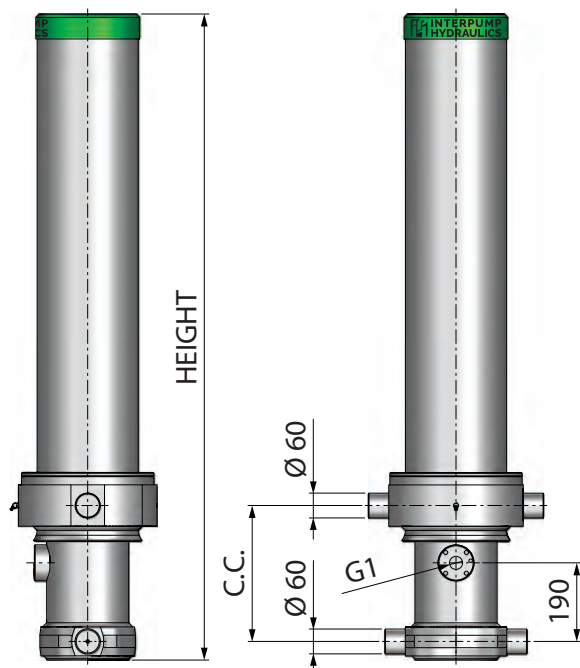

REPAIR KIT

DIAM	EXTENSION N.	GUIDES KIT	SEALS KIT
116	3	K141001163003	K241001163004
116	4	K141001164002	K241001164004
135	3	K141001353005	K241001353003
135	4	K141001354007	K241001354005
154	3	K141001543002	K241001543002
154	4	K141001544004	K241001544003
154	5	K141001545005	K241001545004
174	4	K141001744002	K241001744002
174	5	K141001745002	K241001745003
174	6	K141001746005	K241001746005
196	5	K141001965002	K241001965002
196	6	K141001966002	K241001966002

MODEL - STROKE DIA - EXT.No.	PART NUMBER	HEIGHT [mm]	C.C. [mm]	WEIGHT [kg]
HPFC3820 116 3	4C14701163003	1622	324	165
HPFC3490 135 3	4C13601353002	1480	327	180
HPFC3820 135 3	4C14701353002	1626	328	190
HPFC4270 135 3	4C16801353001	1796	327	210
HPFC3450 135 4	4C10551354002	1181	332	160
HPFC4150 135 4	4C12351354002	1356	332	180
HPFC4650 135 4	4C13601354001	1480	327	190
HPFC4930 135 4	4C14301354003	1551	339	200
HPFC3800 154 3	4C14701543001	1630	330	255
HPFC4010 154 4	4C12101544001	1326	341	226
HPFC4500 154 4	4C13101544002	1449	329	245
HPFC4640 154 4	4C13601544001	1484	332	250
HPFC4930 154 4	4C14301544001	1555	337	260
HPFC5010 154 4	4C14701544001	1630	330	270
HPFC5390 154 4	4C16001544001	1726	339	285
HPFC5690 154 4	4C16801544002	1800	332	295
HPFC4580 154 5	4C11151545001	1241	335	230
HPFC5460 154 5	4C12801545002	1416	316	258
HPFC6160 154 5	4C14301545001	1556	338	286
HPFC7110 154 5	4C16801545001	1801	332	320
HPFC4490 174 4	4C13101744001	1455	335	305
HPFC4630 174 4	4C13601744001	1490	341	305
HPFC6190 174 4	4C18001744001	1936	331	390
HPFC5450 174 5	4C12801745004	1491	342	315
HPFC5620 174 5	4C13101745001	1455	335	315
HPFC5800 174 5	4C13601745001	1491	342	320
HPFC6150 174 5	4C14301745002	1562	329	335
HPFC6730 174 5	4C16001745002	1733	339	365
HPFC7100 174 5	4C16801745002	1807	339	380
HPFC7350 174 5	4C17301745001	1856	340	395
HPFC7750 174 5	4C18001745002	1937	332	405
HPFC8100 174 5	4C18801745001	2007	318	420
HPFC9030 174 5	4C20601745001	2212	338	455
HPFC7380 174 6	4C14301746002	1562	329	355
HPFC5780 196 5	4C13601965001	1504	333	390
HPFC6230 196 5	4C14701965002	1650	338	423
HPFC6710 196 5	4C16001965003	1746	343	445
HPFC7080 196 5	4C16801965001	1820	325	460
HPFC6740 196 6	4C13101966001	1470	343	395

FRONT MOUNT

SINGLE ACTING HYDRAULIC TELESCOPIC CYLINDER

STANDARD RANGE

Value Element	Value Defined
Endurance	Augmented Cylinder Longevity
Payload	More Weight per Load
Tipping Time	More Loads per Day
Service Intervals	Increased Vehicle Working Time

Features	Benefits
Superior Quality Steel	Durability and Strength
Dimensions	Improved Strength
Final Stage Chroming	Corrosion Free with Superior Seal Life
Reduced Weight	Greater Payload
Reduced Oil Volume	Increased Tipping Time and Reduced Oil Cost
Reduced Maintenance	No need of Air Bleeding
Superior Sealing	No Oil Leakage in any climate
Easy bottom access	Faster re-pack
Dust Cover	Protects the Cylinder from Debris



FRONT MOUNT

SINGLE ACTING HYDRAULIC TELESCOPIC CYLINDER

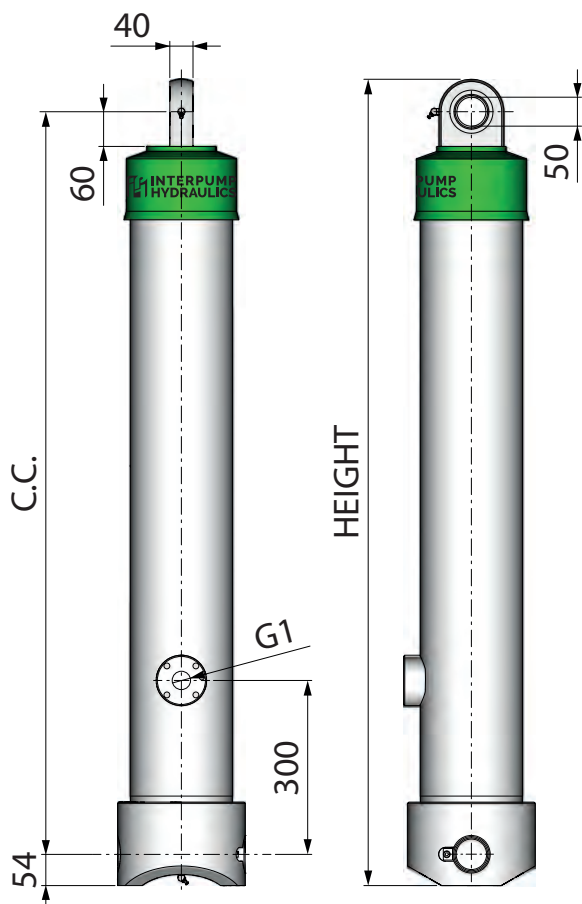

MODEL - STROKE DIA - EXT.No.	PART NUMBER	HEIGHT [mm]	C.C. [mm]	WEIGHT [kg]
HPFB2120 116 3	4B08151163001	1090	980	80
HPFB2760 116 3	4B11151163001	1385	1275	100
HPFB3120 116 3	4B12351163001	1505	1395	110
HPFB3490 116 3	4B13601163001	1629	1519	120
HPFB2760 135 3	4B11151353001	1389	1279	125
HPFB2740 154 3	4B11151543001	1391	1281	155
HPFB3270 154 3	4B12801543001	1566	1456	175
HPFB4010 154 4	4B12101544001	1477	1367	175
HPFB3770 174 4	4B11551744001	1423	1313	205
HPFB4630 174 4	4B13601744001	1637	1527	235
HPFB4910 174 4	4B14301744001	1708	1598	245
HPFB5450 174 5	4B12801745001	1569	1459	240
HPFB5600 196 5	4B13101965002	1607	1497	290

REPAIR KIT

DIAM	EXTENSION N.	GUIDES KIT	SEALS KIT
116	3	K141001163003	K241001163004
116	4	K141001164002	K241001164004
135	3	K141001353005	K241001353003
135	4	K141001354007	K241001354005
154	3	K141001543002	K241001543002
154	4	K141001544004	K241001544003
154	5	K141001545005	K241001545004
174	4	K141001744002	K241001744002
174	5	K141001745002	K241001745003
174	6	K141001746005	K241001746005
196	5	K141001965002	K241001965002
196	6	K141001966002	K241001966002